

Power Analyzer Model 380801

Power Analyzer Datalogger Model 380803

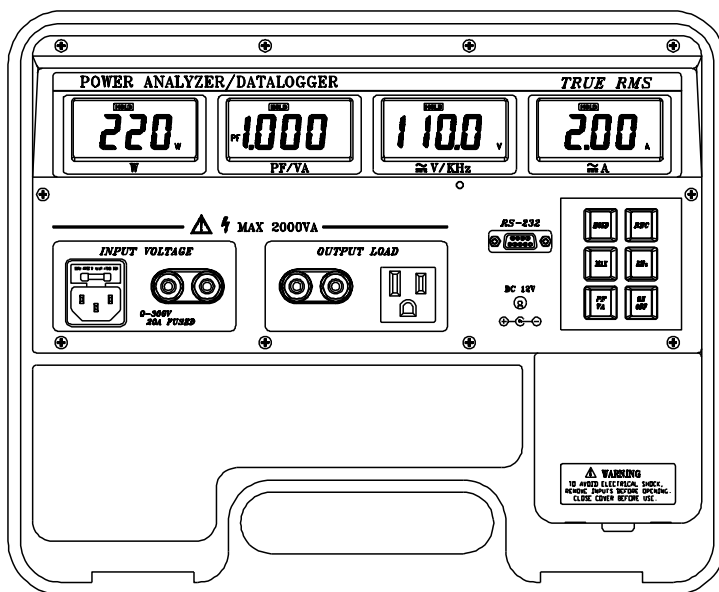

Introduction

This device offers the following features:

- Convenient front panel plug-in and testing
- Four displays for Watts, PF/VA, V/KHz, Amperes
- True power, true RMS for AC Voltage (V) and Current (A)
- Datalogger stores over 1000 readings (Model 380803)
- Auto Range for Watts and Volts
- RS-232 PC Interface (9-pin PC COM port)
- Windows XP compatible Application Software

Careful use of this meter will provide years of reliable service.

Meter Description

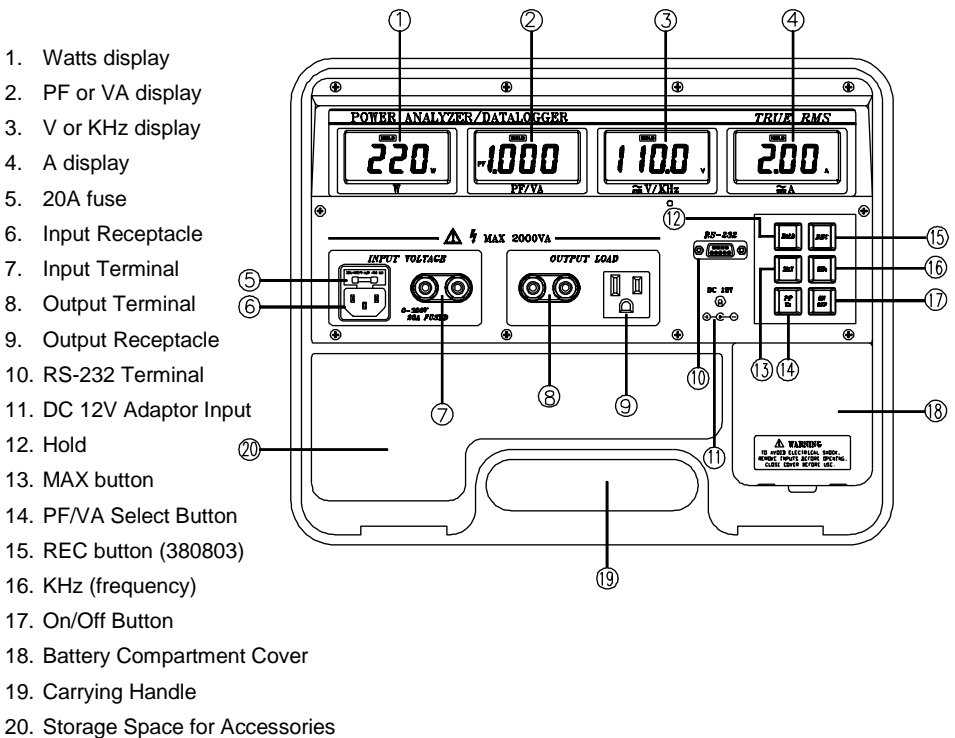

Basic Operation

Warning: If a power source of 220V is connected to the input voltage terminal/receptacle, do not connect a 110V device to the output load terminal/receptacle.

Using Receptacles

1. Plug one end of the power cord into the input receptacle and plug the other end into the wall outlet.
2. Plug the device to be tested into the output load receptacle. The display will show the W, PF, V, and A for the device under test.

Note 2: $W = VA$, $1KW = 1KVA = 1000W = 1000VA$, when $PF = 1$.

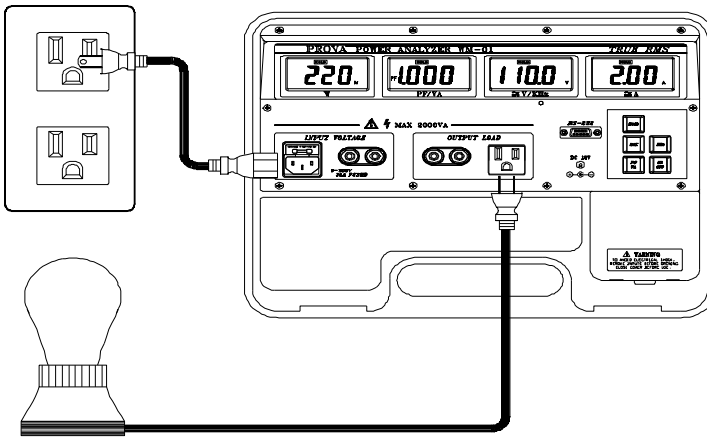

Warning: The input receptacle and terminal are connected in parallel (as are the outputs). To avoid electrical shock, do not touch any metal part of the receptacle or terminal.

Using Terminals

1. Plug one end of the power leads into the input voltage terminal (left) and connect the other end of the test leads to the power source.
2. Plug the device power leads into the output load terminals. W, PF, V, and A will display for the device under test.

Note 2: $W=VA$, $1KW = 1KVA = 1000W = 1000VA$, when $PF = 1$ at DC

Warning: The input and output receptacle and terminal are connected in parallel, Do not touch any metal part of the receptacle or terminal to avoid electrical shock.

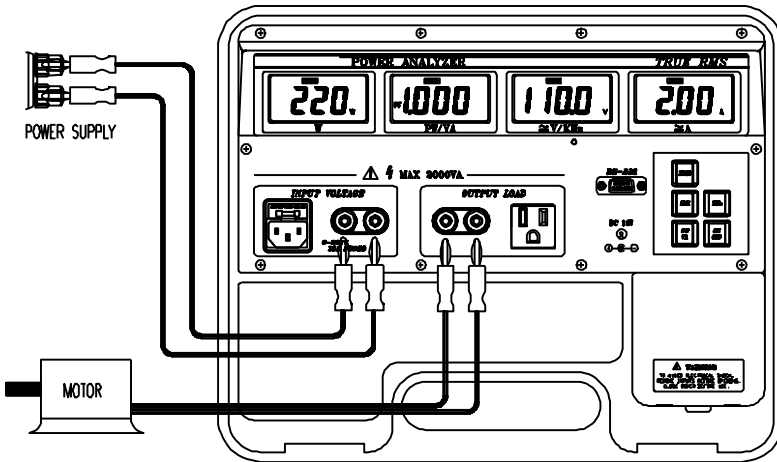

Using a Current Transformer

Warning: Only personnel well trained in the principles of Current Transformers (CT) should attempt this test connection. When connecting a CT, follow the wiring diagrams and instructions below.

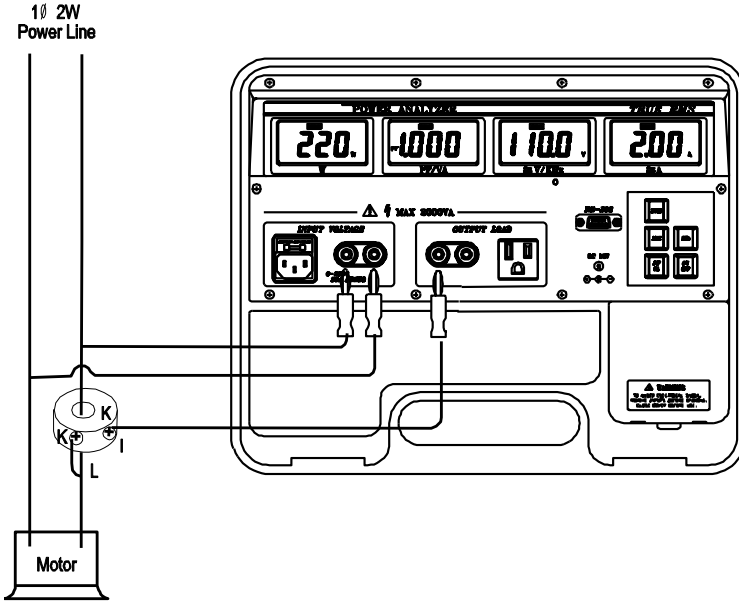

1. Connect the CT's *k* terminal (entering the CT) to the power line that passes through the CT, and connect this *k* terminal to the **input voltage black terminal** (ground).
2. Connect the other power line to the input voltage red terminal.
3. Connect the CT's *I* terminal (leaving the CT) to the output load black terminal (ground).
4. The Watt reading and Amp reading should be multiplied by the CT ratio. The V and PF readings do not need to be multiplied by the CT ratio.

Warning: The input receptacles and terminals are connected in parallel (as are the outputs). Do not touch any metal part of the receptacle or terminal.

PC Interface for Data Acquisition & Datalogging Features

Data Acquisition

Models 380801 and 380803 can be connected to a PC where readings can be logged in real-time as they are taken. Transferred reading data can be viewed, plotted, statistically analyzed, printed, saved, and imported in spreadsheet, database, word processing, and other software programs. Instructions for Data Acquisition are included in the separate Data Acquisition and Datalogging Manual on the software disc.

You can download a copy of the program from www.Extech.com.

Note: Due to the older version of software, this meter can only operate on Windows XP and must use a 9-pin COM port on a Desk top PC as it requires the full +/- 10 volt RS232 signal in order to operate. A USB adapter cannot be used with this meter.

Datalogging (Model 380803 only)

The Model 380803 has built-in memory where over one thousand readings can be stored for later transfer to PC. Once transferred, data can be viewed, plotted, statistically analyzed, printed, saved as a text file, and imported in spreadsheet, database, word processing, and other software programs. Instructions for Datalogging are included in the separate Data Acquisition and Datalogging Manual.

Replacement of Batteries and 20A Fuse

Battery Replacement

When the low battery symbol is displayed on any of the LCDs, replace the eight (8) 1.5V 'AA' batteries.

1. Turn off the power analyzer.
2. Open the battery compartment by using a screw driver (see diagram).
3. Replace the batteries.
4. Replace the battery compartment.

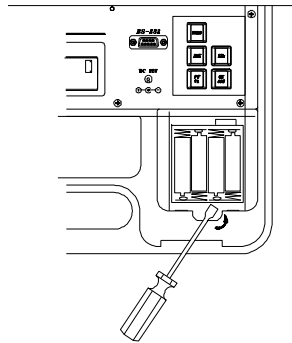

Never dispose of used batteries or rechargeable batteries in household waste.

As consumers, users are legally required to take used batteries to appropriate collection sites, the retail store where the batteries were purchased, or wherever batteries are sold.

Disposal: Do not dispose of this instrument in household waste. The user is obligated to take end-of-life devices to a designated collection point for the disposal of electrical and electronic equipment

20A Fuse Replacement

To replace the 20A fuse, remove the fuse cover as indicated in item (5) in the Meter Description section earlier in this manual and replace the fuse if necessary.

Warning: Do not replace the blown fuse with a fuse rating greater than 20A.

Glossary of Terms

W	True Watt
PF	Power Factor
V	True RMS Voltage
A	True RMS Ampere
Phase angle	Time difference between V and A calculated by \cos^{-1} (Power Factor)
VA	Apparent Power ($V * A$)
VAR	Reactive Power ($\text{SQRT}[VA^2 - W^2]$)
IR	Equivalent current (through equivalent resistance)
Req	Equivalent resistance
IL	Equivalent current (through equivalent inductance)
XL	Equivalent impedance of equivalent inductance
Leq	Equivalent inductance
CAP	Required capacitance
CR	Carriage Return
LF	Line Feed
EPS	Datalogger Memory Self-test
EPE	Erasing Datalogger Memory
$W_{3\phi}$	True Power (3ϕ 3W)
W_{RS}	Power of R phase with respect to S phase
W_{TS}	Power of T phase with respect to S phase
$VA_{3\phi}$	Apparent Power (3ϕ 3W and Balanced Load)
$VAR_{3\phi}$	Reactive Power (3ϕ 3W and Balanced Load)
$PF_{3\phi}$	Power Factor (3ϕ 3W and Balanced Load)
Mean	Mean Value
Std Dev	Standard Deviation
Best Fit	A line drawn to fit a curve with minimum error

Measurement of 3-Phase 3-Wire Power

Using One Power Analyzer

Measure W_{RS} first (RST phases must be correctly identified)

1. Connect the R-phase of the power source to the black terminal of the input voltage
2. Connect the S-phase of the power source to the red terminal of the input voltage
3. Plug the R-phase of the device to be tested to the black terminal of the output load. Do not short the R-phase of the device to be tested to the R-phase of the input power source.
4. Record the reading of W_{RS} displayed on the 'W' LCD.

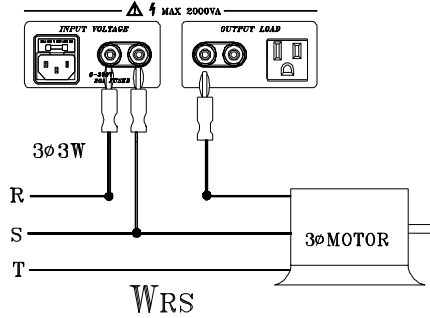

Measure W_{TS} secondly (RST phases must be correctly identified)

1. Connect the T-phase of the power source to the black terminal of the input voltage
2. Connect S-phase of the power source to the red terminal of the input voltage
3. Plug the T-phase of the device to be tested to the black terminal of the output load. Do not short the T-phase of the device to be tested to the T-phase of the input power source.
4. Record the reading of W_{TS} displayed on the 'W' LCD.

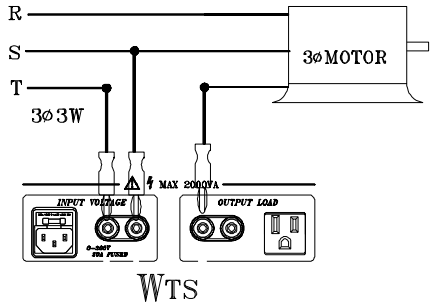

Using Two Power Analyzers

Measure W_{RS} and W_{TS} (RST phases must be correctly identified)

1. Connect the R-phase of the power source to the black terminal of the input voltage of power analyzer 1.
2. Connect the S-phase of the power source to the red terminal of the input voltage of power analyzer 1.
3. Plug the R-phase of the device to be tested to the black terminal of the output load of power analyzer 1. Do not short the R-phase of the load to the R-phase of the input power source.
4. Record the reading of W_{RS} displayed on the 'W' LCD of power analyzer 1.
5. Connect the T-phase of the power source to the black terminal of the input voltage of power analyzer 2.
6. Connect the S-phase of the power source to the red terminal of the input voltage of power analyzer 2.
7. Plug the T-phase of the device to be tested to the black terminal of the output load of power analyzer 2. Do not short the T-phase of the device to be tested to the T-phase of the input power source.
8. Record the reading of W_{TS} displayed on the Watt LCD of power analyzer 2.

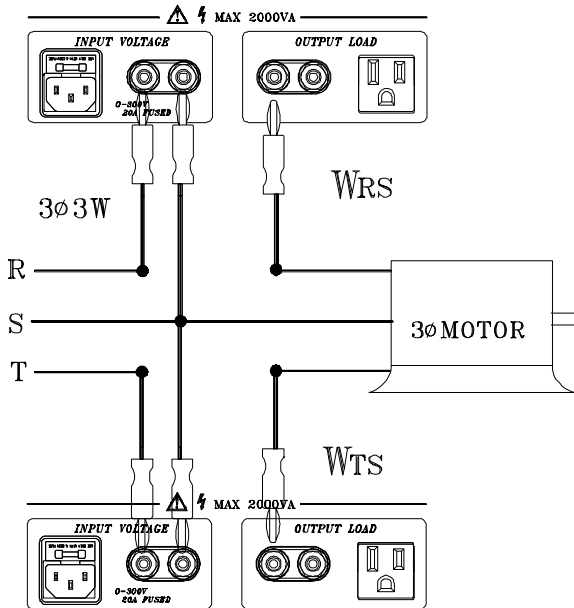

Using Current Transformers (CT) with 2 Power Analyzers

Measure W_{RS} and W_{TS} (RST phases must be correctly identified)

1. Connect the R-Phase to the black terminal of the input voltage of power analyzer 1.
2. Connect the S-phase to the red terminal of the input voltage of power analyzer 1.
3. Connect the k terminal of CT1 to the R-phase.
4. Connect the l terminal of CT1 to the black terminal of the output load of power analyzer 1.
5. The Watt reading of the power analyzer 1 is W_{RS}
6. Connect the T-phase to the black terminal of the input voltage of power analyzer 2.
7. Connect the S-phase to the red terminal of the input voltage of power analyzer 2.
8. Connect the k terminal of CT2 to the R-phase.
9. Connect the l terminal of CT2 with the black terminal of the output load of power analyzer 1.
10. The Watt reading of the power analyzer 2 is W_{TS}

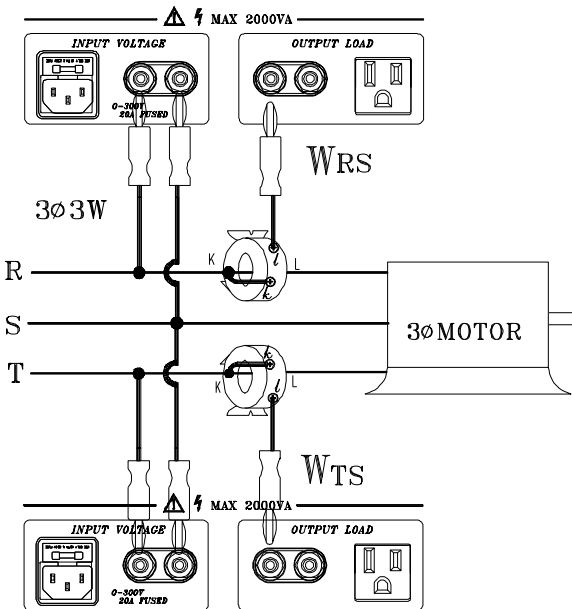

Specifications

WATT (Auto Range, AC+DC, Crest Factor < 5)

Range	Resolution	Accuracy	Input
200W	0.1W	$\pm(0.9\% \text{ reading} + 5\text{digs})$ (50/60Hz) $\pm(5\% \text{ reading} + 9\text{digs})$ (40 to 400Hz)	0-300V, 0-20A, PF=0.5 to 1
2000W	1W		

VOLTAGE (True RMS, Auto Range, AC+DC, Crest Factor < 5)

Range	Resolution	Accuracy	Overload Protection
200V	0.1V	$\pm(0.5\% \text{ reading} + 5\text{digs})$ (40 to 400Hz)	1000VDC/750VAC
750V	1V		

CURRENT (True RMS, AC+DC, Crest Factor < 5)

Range	Resolution	Accuracy (40 to 400Hz)	Overload Protection
2	0.001A	$\pm(0.5\% \text{ reading} + 5\text{digs})$	20A, fused
20	0.01A		

PF (Direct Calculation from W, V, A): $PF = \text{Watt} / (V * A)$

FREQUENCY (Sensitivity 5V)

Range	Resolution	Accuracy
40Hz to 20kHz	1Hz-10Hz	$\pm(0.5\% \text{ of rdg})$ $\pm 2\text{digs}$

Memory Size (380803)	1012 x 4 readings (non-volatile)
Memory Life (380803)	100,000 memory writes
Display	2000 count LCD displays
Over Range Indication	'OL' displayed on LCD
Sampling Rate	2.5 times per second
Power Source	Eight 1.5V 'AA' batteries or AC adaptor
Power Consumption	22 mA approx.
Operating conditions	0 to 40°C (32 to 122°F); Less than 80%
Dimension	13.9"(L) x 11.8"(W) x 3.9" (H) 352(L) x 300(W) x 100(H)mm
Weight	1.637 Kg (3.6 lbs) approx.

Copyright © 2013-2018 FLIR Systems, Inc.

All rights reserved including the right of reproduction in whole or in part in any form
www.extech.com