

User's Guide

EXTECH[®]
INSTRUMENTS

A FLIR COMPANY

True RMS AC / DC Power Clamp Meter

Model 380940

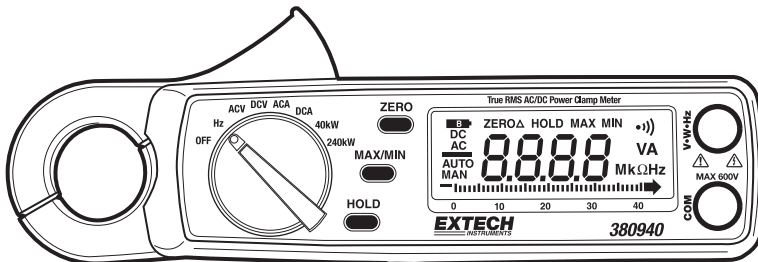







Introduction

Congratulations on your purchase of the Extech 380940 True RMS Watt Clamp DMM. This meter combines multimeter and clamp meter functionality in one convenient meter. Careful use of this meter will provide years of reliable service.

Safety

1. **NEVER** exceed the specified voltage/current maximum
2. **USE EXTREME CAUTION** when working with high voltages.
3. **DO NOT** measure voltage if the voltage on the "COM" input jack exceeds 500V above earth ground.
4. **NEVER** connect the meter leads across a voltage source while the function switch is in the current mode. Doing so can damage the meter.
5. **ALWAYS** discharge filter capacitors in power supplies and disconnect the power when measuring.
6. **ALWAYS** turn off the power and disconnect the test leads before opening the back to replace the fuse or batteries.
7. **NEVER** operate the meter unless the back cover and the battery/fuse door are in place and fastened securely.

International Safety Symbols

	DC Voltage DC Current		Refer to explanation in owners manual
	AC Voltage AC Current		Dangerous voltage risk of electrical shock
	Ground		Double Insulation

Meter Description

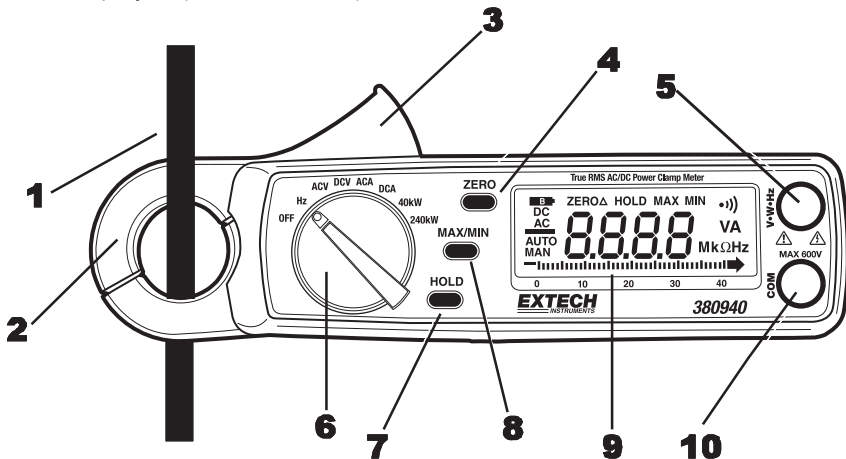

1. Conductor under test
2. Clamp Jaws
3. Jaw trigger – Opens the meter jaws
4. ZERO button – Zeroes the DCA reading
5. Positive input jack (for red test lead)
6. Function select dial
7. HOD button freezes the displayed reading
8. MAX/MIN button – Press to track and view highest and lowest readings
9. LCD Display with function indicators and bargraph
10. COM input jack (for black test lead)

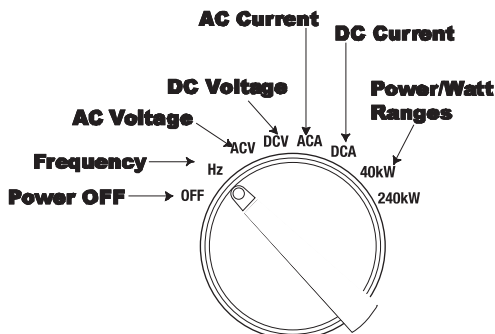

Function Select Switch



Display icons

	Low battery
DC	Direct current
AC	Alternating current
	Minus sign
AUTO	Automatic range (frequency only)
MAN	Manual range
ZERO	Zero / Relative function
HOLD	HOLD function
MAX	Highest reading
MIN	Lowest reading
	Audible continuity
V	Voltage unit of measure
A	Current unit of measure
M	Prefix MEGA (millions of units)
k	Prefix KILO (thousands of units)
Ω	Ohm (unit of measure for resistance and continuity)
Hz	Hertz (unit of measure for frequency)

Bargraph display

The 40 segment bargraph display shown below is a graphical interpretation of the measurement. It is displayed under the display digits on the LCD.

The bars in the bargraph indicate a presence of an electronic signal. The more bars showing, the higher the signal. The digits below the graph help the user see how many bars are showing. If 40 segments are showing, the bars will reach the '40' mark, if 20 bars are showing the bars will reach the '20' mark.

The bargraph is to be interpreted based on the range the meter is in while the measurement is being made. If the bargraph shows 40 segments lit, then the signal is at the highest end of the meter's present range.



Operation

AC + DC Power Watt Measurements

1. Connect the test leads to the voltage source in parallel with the load (refer to diagram).
2. Clamp onto one of the wires connected to the load.
3. Select the AC or DC voltage range using the function select switch and check the voltage reading.
4. Select the AC or DC current range using the function select switch and check the current reading.
5. Select the appropriate Watt range using the function select switch.
6. Read the KW value on the LCD.

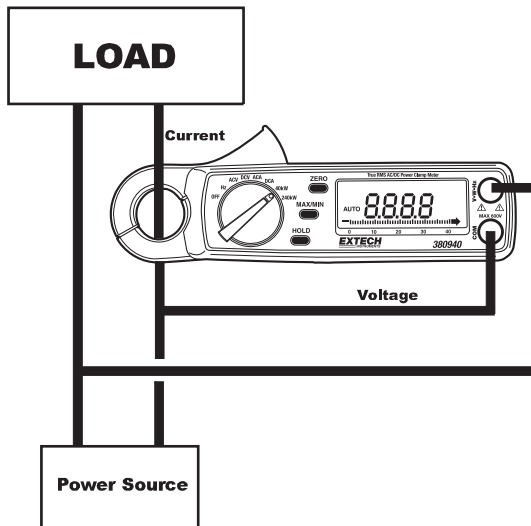

AC Current Measurements

WARNING: To avoid electric shock, disconnect the test leads from the meter before making current measurements.

1. Set the Function switch to the AC Current position.
2. Press the jaw trigger and clamp around a single conductor fully enclosing it. Do not allow a gap between the two halves of the jaw.
3. Read the ACA value on the LCD.

DC Current Measurements

WARNING: To avoid electric shock, disconnect the test leads from the meter before making current measurements.

1. Set the Function switch to the DC Current position.
2. Press the DCA zero key to null the meter display.
3. Press the jaw trigger and clamp around a single conductor fully enclosing it. Do not allow a gap between the two halves of the jaw.
4. Read the DCA value on the LCD.

AC Voltage Measurements

WARNING: To avoid electric shock or damage to the meter, do not make any voltage measurements that exceed the maximum specified.

1. Set the Function switch to the AC Voltage position.
2. Insert the test leads to the meter as follows: Red lead to "V,Ω,Hz" terminal; Black lead to the COM input.
3. Measure voltage with the pointed end of the test leads. Remember that voltage measurements are made in parallel with the device/circuit under test.
4. Read the ACV value on the LCD.

DC Voltage Measurements

WARNING: To avoid electric shock or damage to the meter, do not make any voltage measurements that exceed the maximum specified.

1. Set the Function switch to the DC Voltage position.
2. Insert the test leads to the meter as follows: Red lead to "V,Ω,Hz," terminal; Black lead to the COM input.
3. With the pointed end of the test leads measure voltage. Remember that voltage measurements are made in parallel with the device or circuit under test.
4. Read the DCV value on the LCD.

Frequency Measurements

1. Set the Function switch to the Hz position.
2. Insert the test leads into the meter's input terminals.
3. Connect the other ends of the test leads in parallel with the device/circuit under test.
4. Read the Frequency measurement on the LCD in Hz.

MIN, MAX Function

Pressing the MIN/MAX key allows the meter to display ONLY the highest and the lowest readings encountered. Press the MIN/MAX key once to view the minimum reading, press it again to view the maximum reading. Note that the meter will only change its displayed reading when a measurement is taken higher than the previous MAX or lower than the previous MIN readings. The HOLD display icon (along with the MIN or MAX icon) will appear on the LCD in MIN/MAX mode. Pressing the MIN/MAX key a 3rd time returns the meter to normal operation.

Data Hold

To freeze the current reading on the LCD, press the Data Hold key. To release the Data Hold function and return the meter to normal operation, press the Data Hold key again.

Relative Mode

1. Press the Zero key and the present measurement will Zero.
2. All subsequent measurements are displayed with respect to the zeroed reading. For example, if a 20A reading is zeroed and a 30A reading is subsequently measured, the LCD will display 10A.
3. To return to normal operation, press and hold the zero key for 2 seconds.
4. Note that Relative mode is not available if MIN/MAX mode is enabled.

Auto Power OFF

To extend battery life, the meter will auto power off after 30 minutes of operation. To resume operation either turn the meter OFF and then ON again or press the HOLD button.

Battery Replacement

1. When the low battery symbol appears on the LCD, the batteries must be replaced.
2. Turn the meter off and remove the rear battery compartment screw.
3. Lift off the battery compartment cover and replace the two 1.5V AA cells.
4. Replace the compartment cover and secure the screw.

You, as the end user, are legally bound (**Battery ordinance**) to return all used batteries and accumulators; **disposal in the household garbage is prohibited!**

You can hand over your used batteries / accumulators at collection points in your community or wherever batteries / accumulators are sold!



Disposal: Follow the valid legal stipulations in respect of the disposal of the device at the end of its lifecycle

Cleaning

Use only a dry cloth to clean the plastic case.

Specifications

General Specifications

Display	3-3/4 digit (4000 count) LCD with 40 segment bargraph
Functions	Watts, ACA, DCA, ACV, DCV, Frequency
Polarity	"-" indicates negative polarity; positive assumed
Current sensor	Hall effect sensor type
Overload indication	Left blinking digit
DCA zero adjust	One touch zero key
Display rate	2 readings/second (20 readings/second for bargraph)
Auto Power Off	Meter turns off automatically after 30 minutes
Battery	Two 1.5V AA batteries
Operating temp.	-10°C to 50°C (4°F to 122°F)
Operating Humidity	< 85% RH
Power consumption	Approximately 10mA DC
Weight	190g (6.7 oz) including battery
Dimensions	183 x 63.6 x 35.6mm (7.2 x 2.5 x 1.4") (HWD)
Jaw opening	23mm (0.9") maximum conductor size
Standards	IEC 1010 Category III 300V, Category II 600V

Range Specifications

Function	Range	Resolution	Accuracy	Overload protect
AC Power	40kW	10W	$\pm(1.5\% + 3\text{dgts})$	250V, 400A
	Note: 50/60Hz, PF 0.6 to 1, Vpeak < 360V			
	240kW	100W	$\pm(1.5\% + 3\text{dgts})$	600V, 400A
	Note: 50/60Hz, PF 0.6 to 1, Vpeak < 850V			
	40kW	10W	$\pm(2.5\% + 3\text{dgts})$	250V, 400A
	240kW	100W	$\pm(2.5\% + 3\text{dgts})$	600V, 400A
Note: 40Hz to 100Hz, PF 0.6 to 1, Vpeak < 360V				
Note: 40Hz to 100Hz, PF 0.6 to 1, Vpeak < 850V				
DC Power	40kW	10W	$\pm(1.5\% + 3\text{dgts})$	250V, 400A
	240kW	100W	$\pm(1.5\% + 3\text{dgts})$	250V, 400A
DC Current	400A	100mA	$\pm(1.5\% + 3\text{dgts})$	600A DC
AC Current			50/60Hz	40 to 100Hz
	True RMS, Crest factor < 4	400A	100mA	$\pm 1.5\% \pm 3\text{dgts}$
DC Voltage	400V	0.1V	$\pm(1.0\% + 2\text{dgts})$	800V DC
AC Voltage			50/60Hz	40 to 1kHz
	True RMS, Crest factor < 4, Input impedance 10M Ω	600V	1V	$\pm(1.5\% + 2\text{dgts})$
Frequency	10Hz - 10kHz	0.01- 10Hz	$\pm(0.8\% + 2\text{dgts})$	Sensitivity 10V
				600V AC

Copyright © 2012 Extech Instruments Corporation (a FLIR company)

All rights reserved including the right of reproduction in whole or in part in any form.

www.extech.com